

chromate solutions, etc., is to be accounted for by the presence of *pure oxygen* in these solutions. That such is the case is scarcely to be questioned if the principles of equilibrium reactions are taken into account. In the experimental portion of this paper it is shown that iron as an anode may be rendered passive in highly dilute hydrochloric acid. This is as it should be, when it is recalled that in the electrolysis of hydrochloric acid the proportion of oxygen liberated at the anode increases with dilution.

While the facts shown by Muthman, Heathcote and others, with respect to air or in a vacuum, argue strongly against the existence of an oxide film, they are to be expected if occluded oxygen is the real passive anode. It is, perhaps, not desirable to enter further upon a discussion designed to show how completely the facts accord with the view just presented, but we will content ourselves with a brief and clear restatement.

We consider passivity, not associated with a visible film, to be due to the rate of ionization of certain metals, being insufficient to carry currents of greater than certain densities. When such current density is exceeded, oxygen electrodes, consisting of occluded oxygen, are formed in oxygen electrolytes. Non-anodic passivity is likewise due to occlusion of oxygen and consequent protection of the metal from attack.

UNIVERSITY OF WASHINGTON.

LEAKAGE PREVENTION BY SHIELDING, ESPECIALLY IN POTENTIOMETER SYSTEMS.

By WALTER P. WHITE.

Received July 20, 1914.

This paper describes methods of making insulation more effective in electrical measuring systems by diminishing the influence of disturbing electromotive forces, both external and internal.

These methods, whose principles were known for at least ten years before their application to the potentiometer, are no more needed by the potentiometer than by other instruments of equal delicacy, but are exceptionally effective with it. They are not needed where insulation is quite adequate, as it usually is in dry weather, and an enormous amount of excellent work has certainly been accomplished without them, so that they are sometimes regarded, on first acquaintance, as an unnecessary complication. But in damp weather they have often proved both indispensable and very efficient, yielding results of the highest precision under conditions that would have been nearly hopeless without their aid; while as to complication, the arrangements, once installed, require no attention whatever, and the time of installation, an hour or two, is less than may be required to even locate one of the leakages that might occur through their absence.

The general principle of the methods appears most simply in the prevention of external leakage, that is, of disturbances due to stray currents

from heat, light, or power circuits, etc. Suppose, for instance, that as a result of leakage from 110 volt circuits the top of the table on which a thermoelement is situated is at a potential 60 volts different from a neighboring table, where stands the corresponding potentiometer (Fig. 2a). If insulation is at all defective a current will flow from one table to the other through the measuring system, and some of this will traverse the galvanometer, causing a false deflection. And since the maximum electromotive force of a thermoelement rarely exceeds 0.02 volt, the current due to 60 volts, even if very feeble for such an electromotive force, might be rather large compared to the thermoelement current. An insulation resistance of 5,000,000,000 ohms would usually be needed to prevent it from causing an error of 1 microvolt in the absence of some such arrangement as that to be described.

If Fig. 1 represents, in simplified fashion, the measuring system, and the

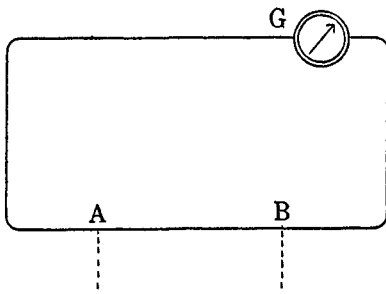

Fig. 1.—Circuit diagram.

leakage current enters and leaves by the two points A and B, the leakage deflection can be reduced in three ways:¹

(a) By improving the insulation. It is, of course, only where this cannot be done sufficiently that other methods are necessary.

(b) By diminishing the resistance A C B, so as to shunt the leakage current away from the galvanometer.

(c) By diminishing the external voltage between A and B.

The last can be accomplished by means of an *equipotential shield*. In the present instance this shield might be two sheets of tin plate, one covering each table, with a wire making connection between the two. The apparatus remains insulated from the plates, just as it was before from the tables. The essentials of the arrangement are shown in Fig. 2, which shows a measuring system first unshielded and then shielded. The leakage current from the exterior voltage cannot now reach the points A and B without first encountering the shield, and, since the shield is a very good conductor, the current will pass along it, but without producing in it any appreciable difference of potential. The shield therefore is an *equipotential* body, and the voltage available for producing a current between A and B has been reduced from 60 volts to a very small and quite negligible fraction of a volt. There is in this case no change in the resistance A B, and none is needed. The protection is practically absolute.

In general, the necessary and sufficient condition of this absolute pro-

¹ A discussion of these methods will be found in "Potentiometer Installation Especially for High Temperature and Thermoelectric Work," *Phys. Rev.*, 25, 340 (1907).

tection is that the shield should interpose itself between the measuring system and the environment at every point where leakage can occur. Leakage ordinarily does not occur through the air, hence protection is needed only where solid bodies are in contact with the system, but in very hot furnaces, where the ionized air conducts, a practically complete boxing in is necessary for perfect protection. Of course electric lights, motors, etc., which may be on either of the tables of our illustrative case, must be shielded off, but this does not mean that the shield must be bent up so as actually to come between the light or motor and the potentiometer. It will do its work quite as well if the motors, etc., merely stand on it. As long as the current cannot reach the measuring system with-

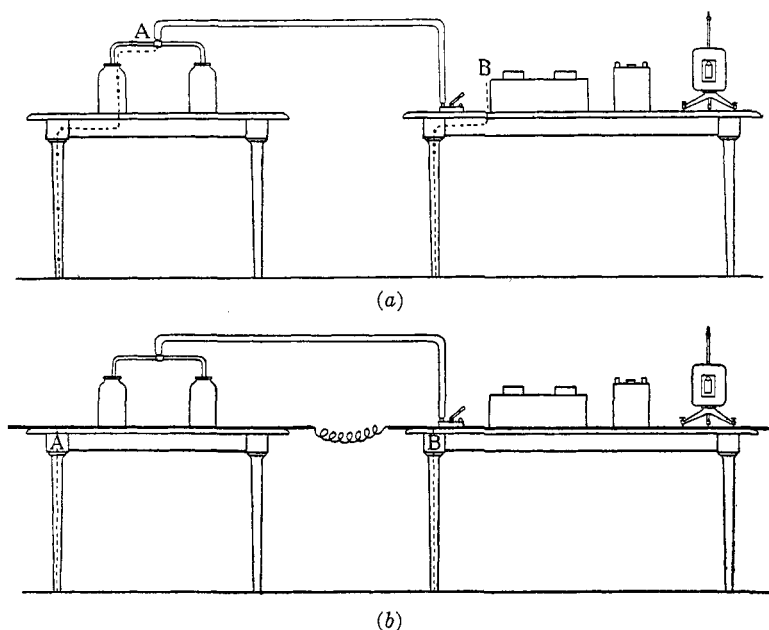

Fig. 2.—Diagram of possible leakage paths in (a) unshielded, (b) shielded, system of apparatus.

out being conducted by the shield (whether through or along it makes no difference) the protection is complete.¹ This of course involves that the motors, etc., must not touch anything which also touches the measuring system, except the shield. For instance, if each is insulated from the shield by linoleum, the linoleum under the potentiometer must be a different piece from the other, otherwise a current might leak along the surface of the linoleum from motor to potentiometer, outflanking the shield. In most cases no trouble would result in this particular way, but this would be due to the insulating power of the linoleum, not to the shield, and the

¹ This necessity may perhaps be satisfactorily expressed by saying that the interposition must be *electrical* but not necessarily *geometrical*.

protection would not be so certain as with the insulating material in two separate pieces.

It may be supposed that the shield would be more effective if "earthed" by connecting (say) to a gas or water pipe, as in electrostatic experiments, but this use of the electrostatic analogy is quite misleading. In electrostatic work the lines of force are often important, and these may run to the walls of the room. These walls are really "the earth" for experiments within that room, and are often conveniently reached through a connection to the iron pipes. With the potentiometer system, on the other hand, all effects through or in the air are (ordinarily) quite negligible; the shield arranged as above described is, with the air, an absolutely complete enclosure as far as concerns the only thing—leakage currents—whose effect is to be prevented; the connecting of pipes or any other external thing to this shield cannot possibly be of any advantage electrically and may prove a harmful complication, introducing another source of leakage currents. *Mechanically*, a pipe system may sometimes prove convenient as part of the shield, and may then perhaps be justified in spite of its electrical disadvantages.

Failure is practically impossible with a properly arranged shield. A proper arrangement is more certain and permanent if the plan is simple, and the connecting wires well soldered, and stout enough to be secure from accidental rupture.¹ Of course those using the shielded apparatus should understand that the connecting of lighting circuits, etc., to anything inside the shield gives a chance for leakage trouble, and ought not to be done without first insuring that no detrimental leakage will result therefrom in that particular case. In the Geophysical Laboratory the tables have metal legs; connecting these legs into the shield shields the table top and everything on it. Wooden tables have been shielded by putting, between the legs and the floor, metal plates, connected to each other and to the rest of the shield by stout and stoutly fastened wires, running down the table legs. The connecting cables are suspended from overhead wires; connecting these wires into the shield shields the cables. Other apparatus is shielded by putting it on metal plates which are connected into the shield, sometimes by suspending it from wires similarly connected or—in the furnaces—by a more or less complete enclosure.

Shielding during Energy Measurements.

There are two cases where the simple and complete form of shield just described must or may be modified. One is where the high voltage circuit must be brought within the shield in order that the potentiometer

¹ It will generally be worth while to arrange the shield so that all its parts are electrically in series, and so that connection can readily be made to the two ends of the line. The integrity of the whole shield can then be easily tested by seeing if a current readily passes through it.

may be used to make measurements upon it. Here the measuring system is kept at a definite potential by the connection with the power circuit, and so is not free to come to the potential of the shield. It is therefore necessary¹ to bring the shield to the potential of the measuring system, which is accomplished by connecting the shield directly to the high voltage circuit very near the point where the measuring system touches it. This insures that the potential of the shield shall not differ much from that of any part of the measuring system, which is, of course, the essential condition for effective shielding.

One other condition is generally necessary in this case. If the current through the measuring coil is that which passes through a heating coil (the commonest application in calorimetry of this sort of measurement), exactly the same current must pass both. This can be insured by connecting the shield to the high voltage circuit just *outside* the measuring connection, and not between measuring coil and heating coil, that is, at H, not K, in Fig. 3.

Then stray currents passing to or from the heating circuit by way of the shield (such as may readily exist, and of relatively large magnitude) will pass around both the coils if they are going to the negative terminal, and through both if to the positive. The current through the heater, therefore, will be correctly measured by the voltage across the other coil, no matter where all of that current comes from. If the connection is to the point K, between the two coils, the same sort of leakage currents will always pass through one and around the other.²

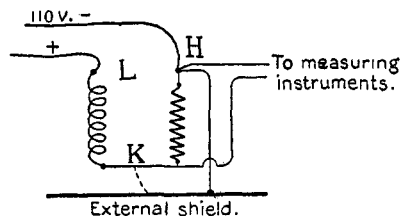

Fig. 3.—Protective connection for high voltage system within the shield. Correct from H, wrong from K.

The current through the heater, therefore, will be correctly measured by the voltage across the other coil, no matter where all of that current comes from. If the connection is to the point K, between the two coils, the same sort of leakage currents will always pass through one and around the other.²

Special Arrangements with Electric Furnaces.

In electric furnaces ionization gives the air a conductivity which increases rather rapidly from 1300° up. Shielding from the heating current therefore requires a conducting enclosure which must be practically complete in the furnace, though it need not be strictly air-tight. Such an enclosure, of course, must usually be of platinum, and is therefore somewhat expensive, as well as often inconvenient. While it is nearly or quite essential for high precision (readings to 1 microvolt or better), it can well be omitted in general. In that case its place inside the furnace is taken by a loose spiral

¹ Necessary, that is, if any shielding is necessary. It is always true that where insulation is quite effective the shield is not needed, but the shield is used, and the present article applies in all cases where a reliance on insulation alone is impossible or undesired.

² Leakage to K from the other terminal, L, of the heating coil will evidently produce the same sort of error as a connection to K. It can be prevented by putting around L an arm of the shield, that is, a small shield connected to the main shield. Cf. "A Test of Calorimetric Accuracy," *Phys. Rev.*, **31**, 687 (1910).

of wire, which gives imperfect protection; but the effect of the shield may be supplemented by the other two methods of controlling leakage mentioned above, namely, improvement of insulation, and shortening of the shorter leakage path in the circuit (A B, Fig. 1).

The length of this shorter path is sometimes controlled by the conditions in the furnace, when both A and B of Fig. 1 lie within the ionized region. Usually, however, the leakage is found to increase in damp weather, which shows that one of the points, say B, is out in the room, since of course the dampest weather does not affect the inside of a furnace heated to 1300°. If, now, a point on the thermoelement just outside the furnace is connected to the shield, the current which leaks into the thermoelement inside the furnace (that is, at A) will run to the shield at once along the new connection, and no longer go on to the former point B. This particular arrangement has sometimes proved useful, but generally fails, because, though it shortens A B of Fig. 1, it also increases the leakage current by providing an easier path for it. Two modifications of the plan, however, are valuable.

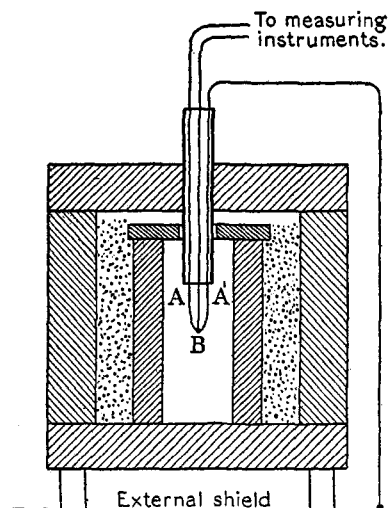

Fig. 4.—Fenner's method of shielding in electric furnaces.

(a) In one the connection to the shield runs into the furnace, and to the very junction of the thermoelement¹ (Fig. 4). Here, though the leakage path is good, the distance A B is exceedingly short; moreover for any leak from A to B there is likely to be a nearly equal leak from A' to B, whose effect on the galvanometer is opposite.² Experience has shown this arrangement to work very well. (b) The second modification of the short connection plan gives a short path A B, and at the same time decreases the amount of leakage. It is obtained by putting an *internal shield* between most of the apparatus and the external shield, making the short connection to this internal shield, and then insulating the whole arrangement. The added insulation can consist of a few hard rubber blocks, simple, accessible, and easily made more effective, as a rule, than the regular insulators of the apparatus. The total leakage will thus be less. At the same time what there is will have to traverse the shield, and hence will take the full metallic path to the shield. This path will be a connection to one of the thermoelement leads, or to the negative potentiometer terminal, hence the path A B will be short. Of course the internal shield must cover all the points, wherever they are, at which leakage from the measuring system to the external shield may take place, and *may* therefore have to be rather extensive. The effectiveness of any part of it can be told by disconnecting that part, and noting the resulting effect on the deflection which is produced by connecting a battery cell between measuring system and external shield at the furnace. The useful-

¹ An arrangement apparently first used by C. N. Fenner, of this laboratory.

² Even if there were no connection to the shield at B, the leak from A to B would still be balanced at the galvanometer by one from A' to B. This is probably the reason why leaks wholly within the furnace are seldom noticeable in ordinary thermoelectric measurements.

ness of this type of internal shield is probably limited to cases where an electric furnace is used.

Internal Battery Shield.

For thermoelectrical work, and in some similar cases, not specially considered here, a different form of *internal shield* is to be recommended, namely, one which diminishes leakages due to the potentiometer battery (or Wheatstone Bridge battery) itself. The ability to gain an advantage through this type of shielding arises from the very low voltage of the thermoelectric reading. This seldom reaches 0.02 volt, hence the potentiometer might be operated by a battery of 0.02 volt electromotive force, which, as far as leakage alone is concerned, would be more advantageous than the present custom. By shielding against most of the battery voltage the leakage can be made no greater than is due to 0.02 volt or less, while the other advantages of an ordinary battery are retained. Of course the leakage with an unshielded 2-volt battery will be considerably less than that coming from the fifty volts or more which often occurs externally. Nevertheless, the battery leakage may evidently be appreciable if the insulation resistance at any one of several points falls much below 100,000,000 ohms; and the battery shield, like other shields, costs very little trouble to instal and none to maintain. It is, therefore, at any rate a method of simplifying matters by eliminating absolutely one possible source of error.

The battery shield is precisely analogous to the external shield as used in power measurements. It shields the whole galvanometer circuit from the rest of the battery circuit and it is kept at the same potential as the galvanometer circuit by a connection to the battery circuit near the galvanometer circuit. It therefore must effect an "electrical" separation (in the sense defined in the second foot-note to this paper) between the galvanometer circuit, on the one hand, and the battery, with other associated apparatus, on the other. A metal plate under the battery and associated apparatus, or something equivalent, is all that is needed.¹ The plate need not extend under the rest of the galvanometer system. The connection from circuit to shield can be made through the potentiometer (battery) terminal nearest in potential to those potentiometer coils which may lie in the galvanometer circuit, that is, through the terminal nearest in potential to the zero points of the potentiometer dials.²

¹ The necessary conditions are also met, in the case of the battery, if that is suspended by a wire connected to the plate—a very convenient arrangement in many cases. Of course the upper end of the wire should be suitably insulated from other apparatus.

² A connection made to a point between the galvanometer circuit coils and the coil used to balance the standard cell causes the same sort of error as a connection to K in Fig. 3. In general, this cannot happen if the connection is to the potentiometer terminal nearest the zero, but it may occur, if not guarded against, whenever the standard cell coil is in a separate box.

Since the battery shield is connected to the measuring system it must be insulated from the external shield, unless the system is sure to be insulated from the external shield at every other point.

In a combination potentiometer, each battery circuit should be shielded.

Surface Shielding.

Further extensions of the battery shield are often desirable, and are made easy by a different method of arranging the shield, which is admissible in many cases. It has already been seen that wherever insulation is effective shielding is unnecessary, and that this principle is applicable to the air, which (usually) is the seat of no leakage. The same thing is true of the *interior* of blocks of hard rubber, porcelain, etc. All the leakage that goes by these passes over their surfaces. With them, therefore, shielding is quite complete which intercepts all the surface leakage, and this may be very easily and effectually done by simply pasting strips of tinfoil on the surface, connecting these, if necessary, to the other parts of the shield.

The Battery Shield and the Eliminating Switch.

In making the adjustment or eliminating parasitic E. M. F.'s¹ from the galvanometer circuit, the usual treatment of the battery current has been either simply to interrupt it, or, with potentiometers of lower resistance, where interruption would impair the constancy of the voltage, to switch the current through another resistance equal to the potentiometer. In either case there will sometimes be, between different parts of the switch, potential differences equal to the whole battery voltage. It will then be necessary, if the insulation cannot be thoroughly relied on, first, to bring the battery shield into the switch, by surface shielding or otherwise, in such a way that when the switch is open the two or three terminals with their leads shall be completely shielded from each other, and second to put the switch at the opposite end of the potentiometer from the shield connection, since it is evident that a shield connected at the same end cannot prevent the leakage current through the open switch from traversing the potentiometer.

The necessity for shielding in the switch is, of course, avoided by the newer arrangement described in connection with Fig. 7 of the previous paper on potentiometers,² where the negative terminal of the battery is merely shifted from the negative potentiometer terminal to a point just beyond the galvanometer circuit coils so as to eliminate these coils, and these only, from the battery circuit. All parts of the switch then remain at nearly the same potential. The substitute resistance is also usually avoided, though if the slight change of current due to the side-tracking of

¹ As described in the first paper of this series, Sec. 5; *THIS JOURNAL*, 36, 1859 (1914).

² *THIS JOURNAL*, 36, 1876 (1914).

the few coils should make the battery a little inconstant, a *small* substitute resistance can be put in series with the extra terminal. With this arrangement the switch must come between the potentiometer terminal and the connection to the shield, for in that way only is the necessary direct connection of shield to battery circuit preserved. Otherwise, when the intermediate terminal is in use the shield is connected to the battery circuit through the eliminated coils, which are therefore traversed by any leakage current which may be returning by way of the shield.

Leakage on the Potentiometer Top.

A hard rubber potentiometer top, if not carefully shielded from light, may easily become, in the course of a few years, the leakiest part of the measuring system. This trouble, however, can usually be corrected without difficulty. (1) In low range potentiometers, shielding upon the potentiometer top is easy, for (a) the leakage is confined to the external surface, so that tinfoil strips are adequate, and (b) the positive terminals of the potentiometer and of the standard cell coil are the only points far from the negative terminal in potential and therefore the only points to be shielded.

(2) The leaky condition of the hard rubber can also be directly removed by warming the top in one place after another with the radiation from an incandescent light, and then applying melted paraffin. This cure is not permanent, at least not on rubber that has once been leaky; such a treatment has twice needed repetition in the course of three years. The operation, however, is not long nor difficult. A very effective control of leakage by means of it could hardly be called laborious.

Good results in leakage prevention are also reported for the method of occasionally wiping the hard rubber surfaces with dilute ammonia.

In case a new instrument is to be set up it might often be well to cover it with a light-proof case, through the top of which pass rods for operating the switches. The same end is readily attained with a glass-topped potentiometer,¹ by simply laying a black cloth on the glass.

Final Considerations.

In the thermoelectric system described in this and other papers of the present series, leakage has proved to be—barring, of course, accidents and outright mistakes—the only considerable source of unexpected errors. The methods of leakage prevention here described, therefore, increase greatly the certainty and reliability of the system, and, being very simple and easy to instal, are to be recommended. Such of them as have to do with the insulating quality of surfaces need, of course, to be tested, but the tests are not difficult and need not be made often. Battery and other electrolytic leakage is not much affected by the position of the poten-

¹ Walter P. White, *Instrumentenkunde*, 34, 79 (1914).

tiometer switches;¹ hence, it can be tested for by connecting the external line directly to the external shield, setting the switches on zero, and then noticing if any change of deflection occurs on connecting or disconnecting the battery. The connection to the external shield in this test may be omitted if it is certain that the insulation between that and the measuring system will be as good in later work as it is at the time of the test.

The effectiveness of the external shield is certain if the shield is complete and is intact. Furnace leakage through an incomplete shield can be detected by reversing the furnace current, and the resulting false deflection (usually) can be measured by interrupting it.

Summary.

1. An insulation resistance of 5,000 megohms or more is often necessary to prevent serious disturbance of thermoelectric measuring systems from stray portions of power or lighting currents, and the frequently more sensitive resistance measuring system is of course in greater danger still. All such trouble is absolutely prevented by an equipotential shield, which is merely a connected system of metal plates, wires, etc., which interposes itself at every point of solid contact between the measuring system and external bodies. This shield need not be, and preferably should not be, "earthed."

2. Slight modifications of this shield are also useful in electric furnaces, in measurements upon power circuits, and within the potentiometer circuit itself.

3. These arrangements are easy to instal; most of them require no subsequent attention, and all are easily tested.

GEOPHYSICAL LABORATORY,
CARNEGIE INSTITUTION OF WASHINGTON,
WASHINGTON, D. C.

[CONTRIBUTION FROM THE CHEMICAL LABORATORY OF THE UNIVERSITY OF CALIFORNIA.]
**THE VAPOR PRESSURES OF SILVER, GOLD AND BISMUTH
AMALGAMS.**

BY ERMON DWIGHT EASTMAN AND JOEL H. HILDEBRAND.

Received August 10, 1914.

The measurements presented in this paper on the vapor pressure of amalgams of silver, gold and bismuth are a continuation of an extensive study, planned and begun by one of us, of the laws of concentrated solutions from the standpoint of metallic solutions. Measurements on the vapor pressures of zinc amalgams have already been published,² and measurements by others of the electromotive force of amalgam concen-

¹ This statement is here intended to apply only to the case of thermoelectric work, where the maximum change of switch setting is only a few millivolts.

² Joel H. Hildebrand, *Orig. Com. 8th Internat. Congr. Appl. Chem.*, **22**, 147; *Trans. Am. Electrochem. Soc.*, **22**, 319 (1912).